

GP Component

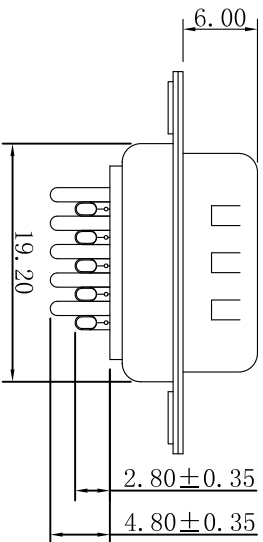
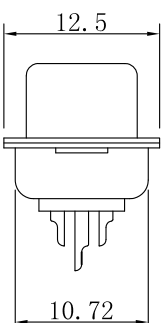
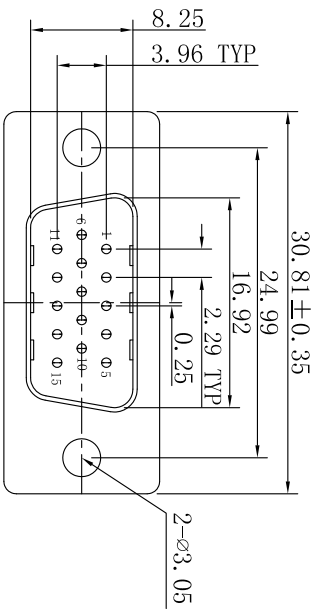
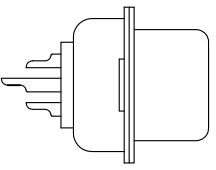
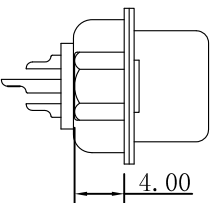
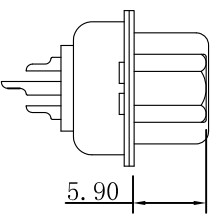

Specification Type

A	B	C
Specification Type		
		

REV.	ECN NO.	LOCATIONS	DESCRIPTION	DATE	DESIGN
A0			原始版本(INITIAL EDITION)	2020.12.01	m t

CHARACTERISTICS:

1. RATED VOLTAGE: 250V AC CD
2. RATED CURRENT: 3.0AMP
3. CONTACT RESISTANCE: 30mΩ Max.
4. INSULATION RESISTANCE: 1000 MΩ MIN. 500V DC
5. Electric Pressure: Keeping 60 second in AC 500V/1mA
6. Operating temperature: -55℃ ~ 105℃
7. INSERTION/EXTRACTION FORCE PER CONTACT: 3.74Kg Max 0.33Kg Min.

01.HDB015 M X XXX XX A XXX

PIN Poles	15:15PIN				
M/F Differentiates	M=Male F=Female				
Hsg Color	1=Black 3=Blue 5=Yellow 2=White 4=Green 6=Purple				
Plating	G00:Gold flash G01:Gold 1U" G03:Gold 3U" Gxx:Gold XXU"	B00:Bright sn B01:Bright sn 1U" B03:Bright sn 3U" Bxx:Bright sn XXU"	M00:Matte sn M01:Matte sn 1U" M03:Matte sn 3U" Mxx:Matte sn XXU"		

 UNITS: mm [inch]	 东莞市跃展精密连接器有限公司 Dongguan YueZhan Precision Connectors Co., Ltd	DESIGN: 牟 2020.12.01	PART NAME: HDB 15M系列图
		CHECKED: 牟 2020.12.01	PART NO. 01.HDB015MXXXXXXXXXX
TOLERANCE: X.X ±0.35 X.XX ±0.25 X.XXX ±0.15 Angle ±3.0°	APPROVED: 牟 2020.12.01	DRAW NO.	SHEET NO. 01 OF 01
SCALE:1:1 SIZE:A4			